

**Homework**

Find the surface area.

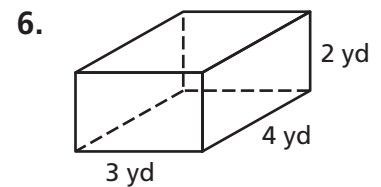
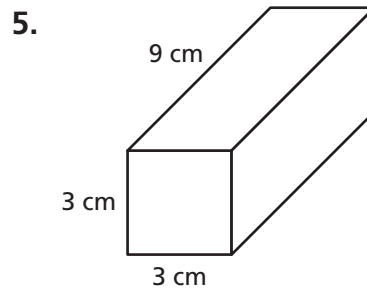
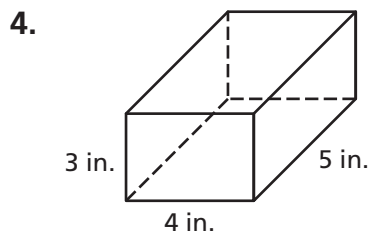
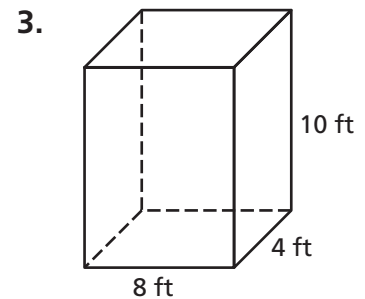
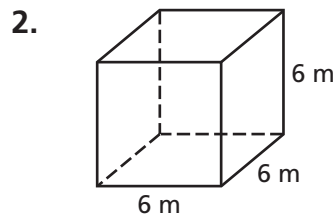
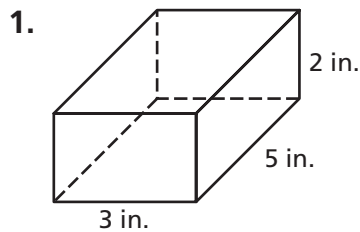

Solve.

7. All the faces of an antique candle box in the shape of a rectangular prism have been painted. The candle box has a length of 25 in., a width of 10 in., and a height of 8 in. What is the total area that was painted?
- \_\_\_\_\_

*Show your work.*

8. Cara made a sewing box in the shape of a rectangular prism. Its length is 14 in., its width is 8 in., and its height is 6 in. Cara plans to cover the box with fabric. The fabric comes in 14 in. squares. How many squares does she need to cover all the faces with no overlap?
- \_\_\_\_\_

# Remembering

Solve.

1. Gerrard is illustrating a children's book. He includes 36 pictures in a book with 45 pages. If he uses the same ratio of pictures to pages, how many pictures will he include if the book has 15 pages?

---

2. Mrs. Lyn is buying wood for a baseboard in the room shown. Then she is going to install wall-to-wall carpeting. How much wood does Mrs. Lyn need? How much carpeting?

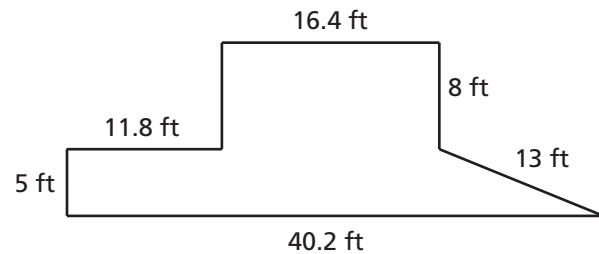

---

Write equivalent fractions. Then compare, add, multiply, and divide the numbers from left to right. Subtract the lesser number from the greater number.

3.	$\frac{5}{9}$	$\frac{3}{5}$	→
4.	>	<	
5.	+		
6.	•		
7.	÷		
8.	−		

9.	$1\frac{5}{6}$	$2\frac{3}{10}$	→
10.	>	<	
11.	+		
12.	•		
13.	÷		
14.	−		

15. **Stretch Your Thinking** Jason is making a toy box in the shape of a rectangular prism. Jason sketches one net. Then he draws another net that has double the dimensions of the first net. How do the surface areas compare? Explain.

---



---



---

**Homework**

Name the prism.

1.

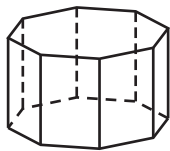

\_\_\_\_\_

2.

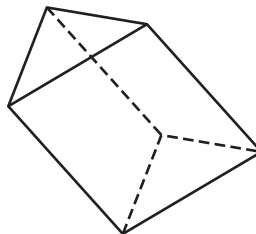

\_\_\_\_\_

3.

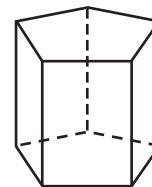

\_\_\_\_\_

4.

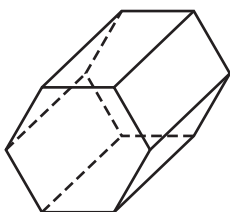

\_\_\_\_\_

5.

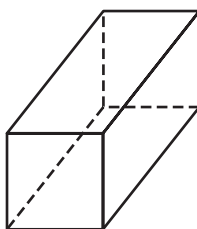

\_\_\_\_\_

6.

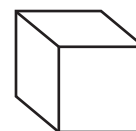

\_\_\_\_\_

**Complete.**

7. Will this net form an octagonal prism? Explain.

\_\_\_\_\_

8. The base of a square prism has an area of  $16 \text{ in.}^2$ . The height of the prism is 6 in. What is the surface area of the square prism?

\_\_\_\_\_

9. The perimeter of the base of a regular octagonal prism is 8 ft. What is the width of a rectangular side of the prism?

\_\_\_\_\_

10. The base of a triangular prism has an area of  $6 \text{ cm}^2$ . The height of the prism is 5 cm. The width of the rectangular faces are 3 cm, 4 cm, and 5 cm. What is the surface area of the triangular prism?

\_\_\_\_\_

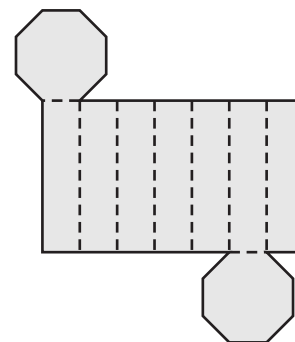

# Remembering

Solve.

1. Lorraine can give 3 customers haircuts in 2 hours. How long will it take her to give 12 customers haircuts?
- \_\_\_\_\_

Complete.

2.  $\frac{5}{6} + \frac{7}{10}$

\_\_\_\_\_

3.  $56.77 + 23.47$

\_\_\_\_\_

4.  $1.2 \cdot 22.3$

\_\_\_\_\_

5.  $1\frac{4}{5} \div \frac{2}{3}$

\_\_\_\_\_

6.  $607.3 - 122.9$

\_\_\_\_\_

7.  $1\frac{2}{9} - \frac{5}{9}$

\_\_\_\_\_

8.  $134.1 \div 3$

\_\_\_\_\_

9.  $15.4 + 55.6$

\_\_\_\_\_

Find the surface area.

10.

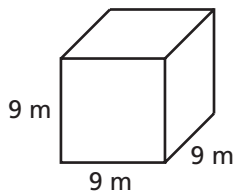

11.

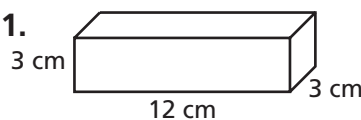

12.

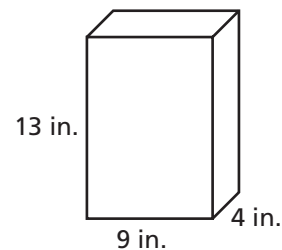

13. **Stretch Your Thinking** Herga makes boxes for games that she has invented. She makes a box for one game. Then she makes a box with dimensions that are one third the dimensions of the first box. What is the relationship between the surface areas of the boxes? Explain.
- \_\_\_\_\_
- \_\_\_\_\_
- \_\_\_\_\_
- \_\_\_\_\_

# Homework

Find the surface area.

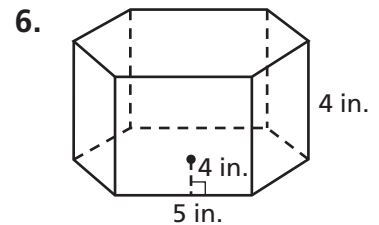
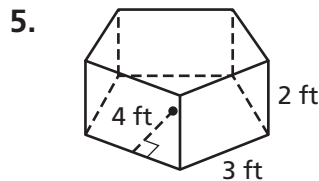
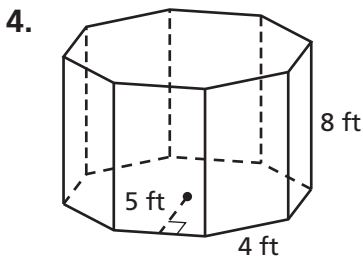
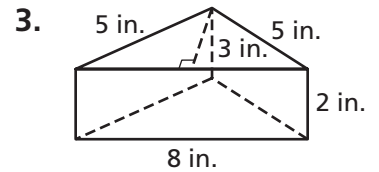
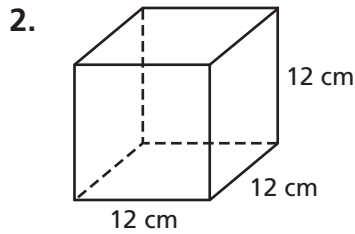
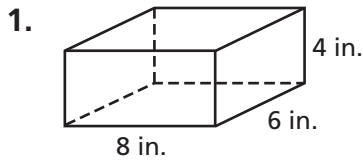

Solve.

7. Jesse bought the speakers shown at the right. All faces of the speakers except the front faces are wood. How many square inches of wood were used to make the speakers?

---

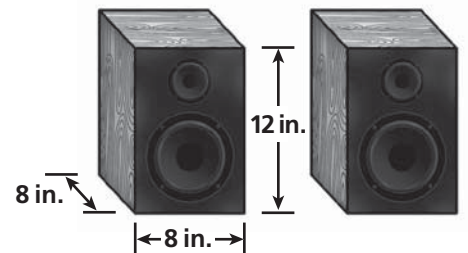

8. The glass entry way to a basement store is shown at the right. How many square feet of glass were used to make the entry way?

---

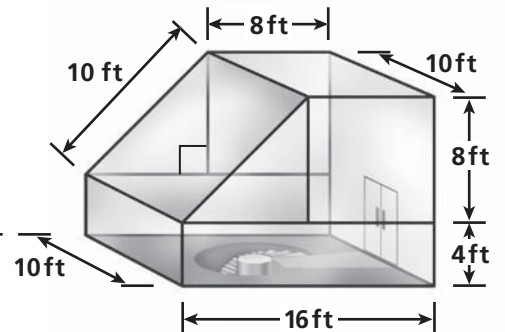

# Remembering

Solve.

1. At Pet Foods, dog food costs \$10 for 5 pounds. At Buydogfood.com, the dog food costs \$9 for 3 pounds. At which store is the food less expensive?

---



---



---

Name the prism.

2.

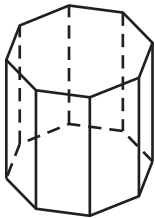

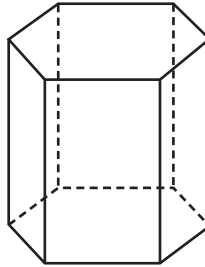

---

3.

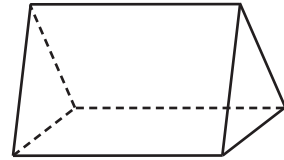

---

4.



---

5. The perimeter of the base of a pentagonal prism is 45 cm. What is the width of the rectangular side of that prism?

---

6. The area of the base of a triangular prism is  $60 \text{ ft}^2$ . The height of the prism is 3 ft. If the widths of the rectangular faces are 8 ft, 15 ft, and 17 ft, what is the surface area of the triangular prism?

---

7. **Stretch Your Thinking** Jerome has a block of craft foam shaped like a square prism. He cuts the foam block in half. Jerome thinks that because the surface area of the original block was  $358 \text{ in.}^2$ , the surface area of each piece is  $179 \text{ in.}^2$ . Is he correct? Explain.

---



---



---

# Homework

These nets form pyramids.

Use the shape of the base to name the pyramid.

1.

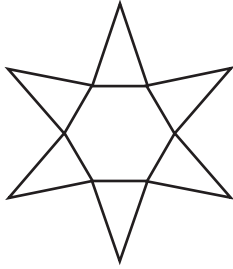

\_\_\_\_\_

2.

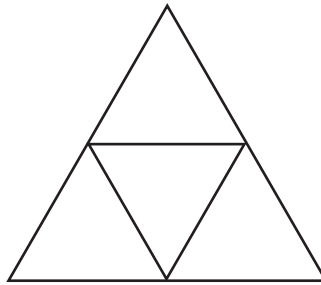

\_\_\_\_\_

3.

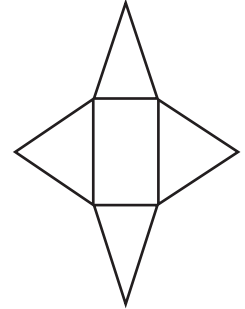

\_\_\_\_\_

4.

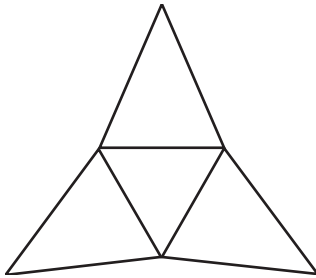

\_\_\_\_\_

5.

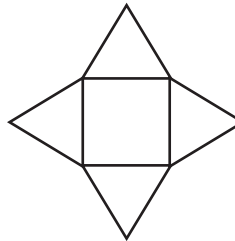

\_\_\_\_\_

6.

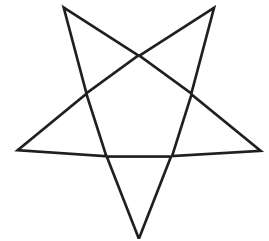

\_\_\_\_\_

**Complete.**

7. Will this net form a triangular pyramid? Explain.

\_\_\_\_\_

8. The perimeter of the base of a hexagonal pyramid is 48 in. The base is a regular polygon. What is the length of the base of one of the triangular faces?

\_\_\_\_\_

9. Vinnie found the area of a triangle with a base of 5 in. and a height of 6 in. to be 30 in.<sup>2</sup> What error did he make?

\_\_\_\_\_

10. Explain how you know how many triangular faces any pyramid will have?

\_\_\_\_\_

\_\_\_\_\_

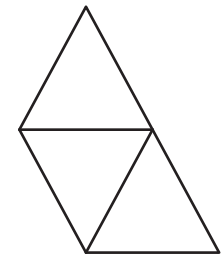

# Remembering

Solve.

- Sammy can read 20 pages in 5 minutes. At this rate, how many pages can she read in 1 minute?

\_\_\_\_\_

- Plot these ordered pairs:  $A(2, 4)$  and  $B(2, 8)$ . Plot point  $C$  so that when you draw lines to form triangle  $ABC$  the base of the triangle has a length of 3 units. If segment  $BC$  is 5 units long, what is the perimeter and area of triangle  $ABC$ ?

$P =$  \_\_\_\_\_

$A =$  \_\_\_\_\_

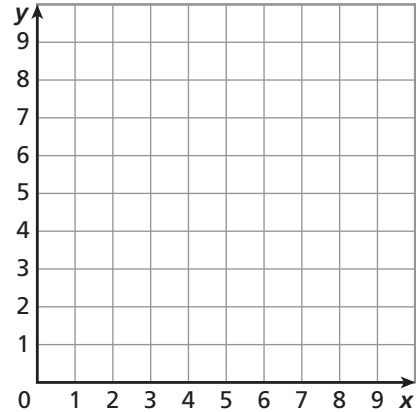

Find the surface area.

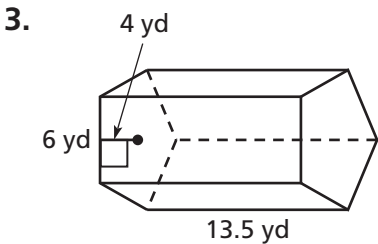

\_\_\_\_\_

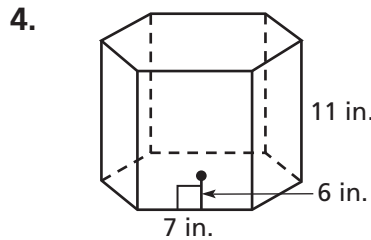

\_\_\_\_\_

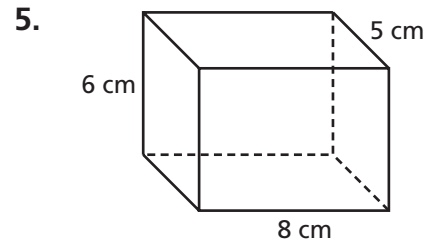

\_\_\_\_\_

- Stretch Your Thinking** Marian glued together the wooden blocks as shown. Then she painted the faces of the blocks. How many square inches of paint did she use? Explain how you found your answer.

\_\_\_\_\_

\_\_\_\_\_

\_\_\_\_\_

\_\_\_\_\_

\_\_\_\_\_

\_\_\_\_\_

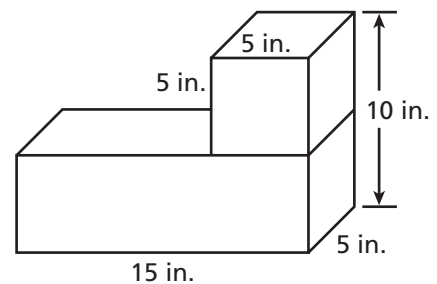



# Homework

Find the surface area. The bases of the pyramids in Exercises 1, 3, 4, 5, and 6 are regular polygons.

1.

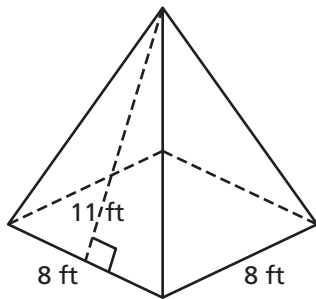

\_\_\_\_\_

2.

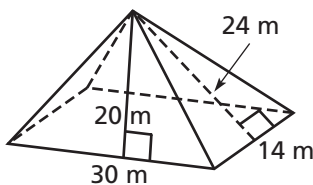

\_\_\_\_\_

3.

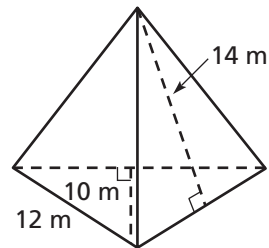

\_\_\_\_\_

4.

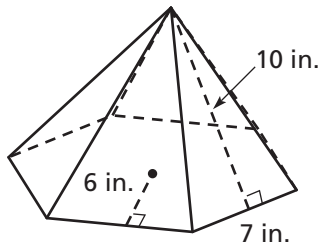

\_\_\_\_\_

5.

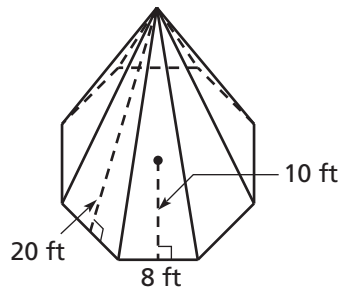

\_\_\_\_\_

6.

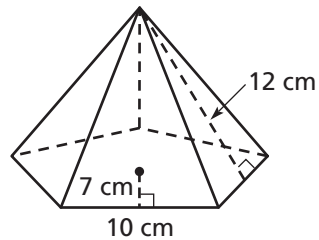

\_\_\_\_\_

**Solve.**

7. The surface area of a square pyramid is  $112 \text{ ft}^2$ . If the length of each edge of the base is 8 ft., what is the slant height of each triangular face?

\_\_\_\_\_

8. The roof of this doghouse is a square pyramid. Each triangular face is 3 ft. high. If Jamal paints the roof and the sides, including the door, how much area will he paint?

\_\_\_\_\_

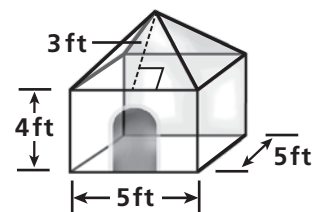

# Remembering

Solve.

1. Barry collects \$24 for every 6 newspaper subscriptions he sells. How much would he collect for 8 newspaper subscriptions?
- \_\_\_\_\_

Complete.

$$\begin{array}{r} 2. \quad 56 \\ \times 1.2 \\ \hline \end{array}$$

$$\begin{array}{r} 3. \quad 456 \\ + 443 \\ \hline \end{array}$$

$$\begin{array}{r} 4. \quad 2,334 \\ - 976 \\ \hline \end{array}$$

$$\begin{array}{r} 5. \quad \frac{10}{11} \\ + \frac{1}{2} \\ \hline \end{array}$$

$$6. \quad \frac{2}{3} \cdot \frac{3}{4}$$

\_\_\_\_\_

$$7. \quad 34.5 \div 0.5$$

\_\_\_\_\_

$$8. \quad \frac{2}{5} \div 1\frac{1}{5}$$

\_\_\_\_\_

$$9. \quad \frac{5}{6} - \frac{1}{3}$$

\_\_\_\_\_

Name the shape of the base and use it to name the pyramid

10.

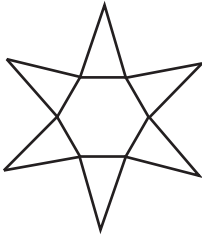

11.

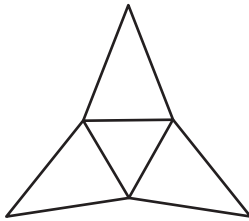

12.

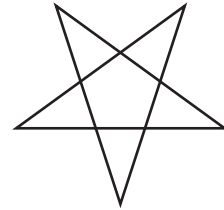

13. **Stretch Your Thinking** What is the least number of faces that a pyramid can have? Explain.
- \_\_\_\_\_
- \_\_\_\_\_
- \_\_\_\_\_
- \_\_\_\_\_

# Homework

Gina wants to make a pyramid container to hold popcorn.



1. Sketch below a small net for a pyramid container that will hold popcorn. Label the net with the actual dimensions you would like your container to have.

2. Use your net to find the surface area of your popcorn pyramid container.
-

# Remembering

Solve.

- Mr. O'Neil can buy a box of 8 pens for \$24 at the ABC store. He can buy a box of 6 pens for \$12 at the XYZ store. Mr. O'Neil wants to buy the pens for the lowest possible price. At which store should he buy the pens?

---



---



---

Name the pyramid. Then find the surface area.

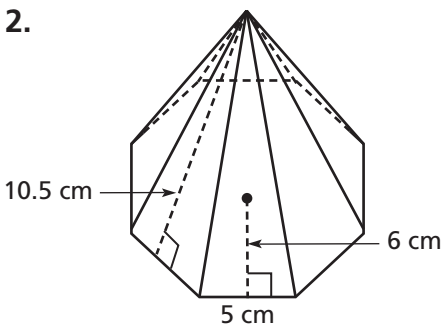

---



---

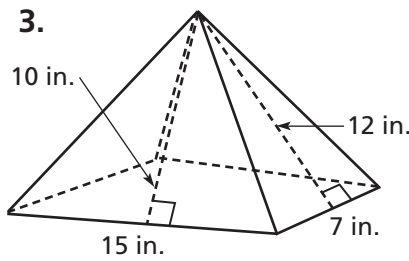

---



---

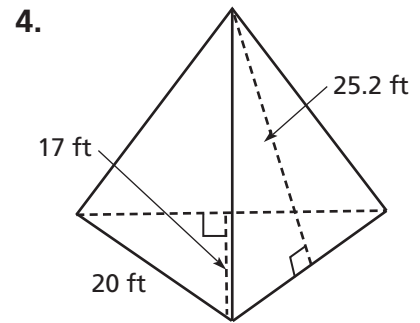



---

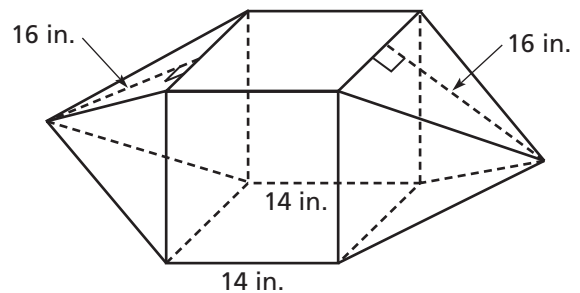

---

- Stretch Your Thinking** Millie made the marble sculpture shown. She will treat the outside faces of the sculpture with marble protectant. How many square inches of the sculpture need to be treated? Explain how you found your answer.



---



---



---



---